

The divided cell algorithm and the inhomogeneous Lagrange and Markoff spectra

Richard T. Bumby* and Mary E. Flahive†

*Rutgers, the State University of New Jersey, Department of Mathematics, Hill Center, Busch Campus, 110 Frelinghuysen Road, Piscataway, NJ 08854-8019, USA

†Department of Mathematics, Kidder Hall, Oregon State University, Corvallis OR 97331-4605, USA

Abstract. The divided cell algorithm was introduced by Delone in 1947 to calculate the inhomogeneous minima of binary quadratic forms and developed further by E. S. Barnes and H. P. F. Swinnerton-Dyer in the 1950s. We show how advances of the past fifty years in both symbolic computation and our understanding of homogeneous spectra can be combined to make divided cells more useful for organizing information about inhomogeneous approximation problems.

A crucial part of our analysis relies on work of Jane Pitman, who related the divided cell algorithm to the regular continued fraction algorithm. In particular, the relation to continued fractions allows two divided cells for the same problem to be compared without stepping through the chain of divided cells connecting them.

Keywords: continued fraction, inhomogeneous Markoff Spectrum

PACS: 02.10.De; **MSC:** 11J70, 11J06, 11H16

1. PRELIMINARIES

Notational conventions and a basic framework for working with approximation problems are collected here for the convenience of the reader.

Diophantine Approximation problems deal with finding where the restriction of a function to a special subset is small. In this paper, the function will be defined on the plane \mathbb{R}^2 and the subset will be the integer lattice \mathbb{Z}^2 . The function will take nonnegative values, so “small” will mean “close to zero”. It is customary to work with the reciprocal of the original function, and to freely treat $\infty = 1/0$ as a number, since it will be a possible value of the supremum of a set of nonnegative numbers.

By working with the name denoting a function instead of the traditional convention of denoting a sequence with subscripts, we are allowed the uncluttered notation $\limsup f$ to denote the infimum over all cofinite subsets S of \mathbb{N} of the supremum of the values of f restricted to S .

The computation of the infimum of a function can often be organized by endowing the domain with a *partial order* for which the given function is order preserving. If the partial order has the property that descending sequences are finite, then the infimum of the values over the whole set is equal to the infimum over the set of *minimal points* for the partial order. This is valuable when the set of minimal points has special properties. In particular, it is usually possible to index the minimal points by the set of all integers \mathbb{Z} so that a pair of adjacent minimal points has some special property. Such a function defined on set of all integers \mathbb{Z} will be called a *chain*.

The integer lattice in \mathbb{R}^2 is identified with \mathbb{Z}^2 by giving it a basis. Certain bases aid in the identification of the minimal points. These depend on the expression and have been called *reduced*. Dually, the expression giving the function in terms of a reduced basis has also been called reduced.

Families of related problems lead to a space of reduced bases, and the study of all reduced bases for a single problem can be expressed in terms of a dynamical system on this space. This study will lead to strong results when the underlying space is *compact*.

Our emphasis here will be *visual* with pictures of the plane \mathbb{R}^2 including the lattice \mathbb{Z}^2 . However, while a basis for the lattice is used in the algebraic description of the objects in the figure, other considerations may be used in the choice of *viewing coordinates*.

2. THE MARKOFF SPECTRUM

Traditionally, as in [5], the homogeneous *Markoff Spectrum* is the set of values

$$M(F) = \sup \left\{ \frac{\sqrt{D(F)}}{|F(x,y)|} : x, y \in \mathbb{Z}, (x,y) \neq (0,0) \right\} \quad (1)$$

where $F(x,y) = Ax^2 + Bxy + Cy^2$ is an *indefinite* binary quadratic form of discriminant $D(F) = B^2 - 4AC$. The quantity $M(F)$ is given as a *normalized inverted minimum*: *normalized* to allow natural comparison between values of different forms F ; *inverted* to allow simpler expressions for interesting values in the spectrum. Those F with $F(x,y) = 0$ for integers x and y (not both zero), as well as those taking arbitrarily small values, have $M(F) = \infty$. The interesting cases are those for which $M(F)$ is finite.

Since F is indefinite, it can be factored over \mathbb{R} . We write

$$F(x,y) = (a_0x + b_0y)(a_1x + b_1y), \quad (2)$$

and introduce new variables $\xi = a_0x + b_0y$, $\eta = a_1x + b_1y$ to get $F = \xi\eta$. Then, $\sqrt{D(F)} = |a_0b_1 - a_1b_0|$.

In particular, the expression $F(x,y)$ is encoded by the matrix

$$A = \begin{bmatrix} a_0 & b_0 \\ a_1 & b_1 \end{bmatrix}. \quad (3)$$

Left multiplication by this matrix takes the column with components (x,y) to one with components (ξ,η) . Thus, it gives a change of variables between the arithmetic and geometric aspects of the study of the values of F on the integer lattice. The rows of the matrix are the coefficients in the factors of $F(x,y)$. As a change-of-variables matrix, its columns give the (ξ,η) coordinates of the generators of the lattice.

A change of basis in the lattice multiplies the matrix in (3) on the right by an integer matrix of determinant ± 1 ; scaling the factors of $F(x,y)$ multiplies on the left by a real diagonal matrix. The value of $M(F)$ is not changed by these actions.

A *visual* approach to the Markoff Spectrum must show the integer lattice and the lines $a_ix + b_iy = 0$ ($i = 0, 1$). However, it is more convenient to use (ξ,η) as *viewing coordinates* since a *fixed* F will be studied using *different bases* for the integer lattice. In practice,

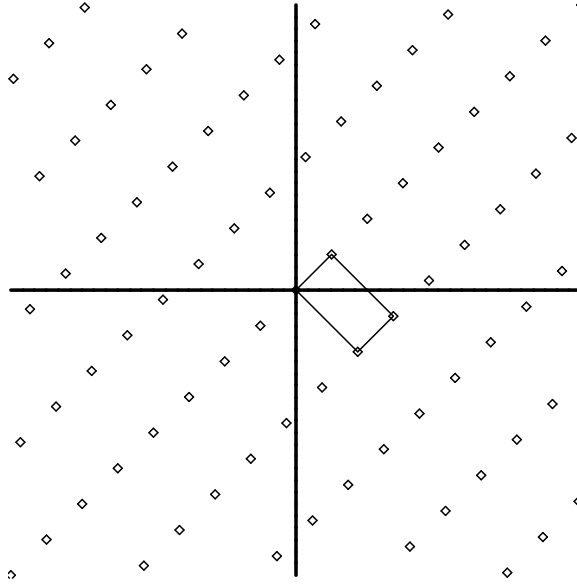

FIGURE 1. Homogeneous example

this may be modified by a change of scale $(\xi, \eta) \rightarrow (a\xi, \eta/a)$ in order to bring different lattice points into focus. Because of this choice of viewing coordinates, the lines where $F(x, y) = 0$ will be called the *axes* of F . For example, a picture of $F(x, y) = x^2 - 3y^2$ on the integer lattice uses viewing coordinates (ξ, η) with $\xi = x + y\sqrt{3}, \eta = x - y\sqrt{3}$. Figure 1 shows this view of $F = 0$ (now just the coordinate axes), the lattice generated by $(x, y) = (1, 0)$ and $(x, y) = (0, 1)$, and the lattice cell whose (x, y) coordinates are $(0, 0), (1, 0), (1, 1), (0, 1)$.

In computing $M(F)$, if a lattice point P_0 is closer to both axes than the lattice point P_1 is, then $|F|$ is smaller at P_0 than at P_1 . This relation between P_0 and P_1 is a partial order of the type mentioned in the Preliminaries. Thus, only the *minimal points* for this partial order need be considered when finding $M(F)$. Arranging the minimal points in order of their distance to a specified axis of F gives a *chain* of minimal points (except when an axis contains a nonzero lattice point). Since these results are well known, and have been given in detail in [3], features of this chain are only sketched here. The corresponding results for inhomogeneous problems will be described later in more detail. Figure 1 shows that $(x, y) = (1, 0)$ and $(x, y) = (1, 1)$ are minimal points, but $(x, y) = (0, 1)$ is not since $(1, 0)$ is closer to both axes.

A full description shows that two successive minimal points always generate the lattice. These are the *reduced bases* of the lattice. In a precise definition of a reduced basis, it is convenient to fix the order of the axes, the order of the generators of the lattice, and to choose between a generating vector and its negative. With one set of choices, if x and y are the coordinates with respect to a reduced basis, one has $a_0 \geq a_1 \geq 0$ and $b_1 \geq -b_0 \geq 0$ in (2) and (3). Since the matrix (3) determines the reduced basis, it is appropriate to also speak of a *reduced matrix* when these conditions hold. The inhomogeneous case will also require matrices with $b_0 \geq 0 \geq a_0$, but these are avoided in the tradition treatment of the homogeneous case.

For *three* consecutive minimal points, a matrix whose columns are the basis consisting of the second and third points is the product of the corresponding matrix for the first and second points with the matrix

$$\begin{bmatrix} 0 & 1 \\ 1 & -a \end{bmatrix} \quad (4)$$

with $a = \lfloor a_0/b_0 \rfloor$. To restore orientation and obtain the required signs of the matrix element, this must be multiplied on the left by a diagonal matrix whose first diagonal entry is positive and whose second entry is negative. In the example, when the matrix for the reduced basis $(1, 1), (1, 0)$ multiplied by the matrix in (4) and rescaled, leads to the equation

$$\begin{bmatrix} 1 + \sqrt{3} & 1 \\ 1 - \sqrt{3} & 1 \end{bmatrix} \begin{bmatrix} 0 & 1 \\ 1 & -2 \end{bmatrix} = \begin{bmatrix} -1 + \sqrt{3} & 0 \\ 0 & -1 - \sqrt{3} \end{bmatrix} \begin{bmatrix} \frac{1 + \sqrt{3}}{2} & 1 \\ \frac{1 - \sqrt{3}}{2} & 1 \end{bmatrix}. \quad (5)$$

The space of all reduced matrices with fixed determinant forms a compact set. Note that compactness requires that all inequalities be *inclusive*. Classical work often aimed for unique representations and required some inequalities to be strict, but sacrificing uniqueness to have a compact space of reduced matrices allows the Spectrum to be characterized in terms of *attained* extrema.

The chain of the matrices given by (4) is one description of the steps in the continued fraction algorithm. It produces a *symbolic dynamics* that is useful for describing the relation between the reduced bases of a given form and the computation of $M(F)$. In particular, a consistent choice of a vector from each reduced basis leads to a chain of minimal points (x_n, y_n) , and $M(F) = \sup M_n(F)$ where

$$M_n(F) = \frac{\sqrt{D(F)}}{|F(x_n, y_n)|}. \quad (6)$$

Each index n should be associated with both the minimal point (x_n, y_n) and the reduced basis with this point as first element. A sequence of indices can be found for which $M_n(F) \rightarrow M(F)$ and also the corresponding reductions converge (see Lemma 6 of Chapter 1 of [5]). This shows that every value in the Markoff Spectrum is an *attained* supremum. This result is known as the *Compactness Theorem* for the Markoff Spectrum.

A novel variation on this approach, allowing generalization to higher dimensions, can be found in [4].

The *Divided Cell Algorithm* transfers these properties of the continued fraction to inhomogeneous problems.

3. THE LAGRANGE SPECTRUM

If the form $F(x, y)$ in (2) is $x(y - x\alpha)$, then $F(0, 1) = 0$, giving $M(F) = \infty$. However, if α is irrational, no other *minimal points* (x, y) have $F(x, y) = 0$. If $0 < \alpha < 1$, we set $(x_{-1}, y_{-1}) = (1, 0)$ and $(x_0, y_0) = (0, 1)$, giving a reduced basis; and then index the other minimal points by positive integers. Properties of rational approximations to α are determined by $L(\alpha) = \limsup M_n(F)$ for $n \in \mathbb{N}$. The set of such values is called the

Lagrange Spectrum. Theorem 1 of chapter 3 of [5] says that the Lagrange Spectrum is a subset of the Markoff Spectrum. This follows from the proof of the Compactness Theorem for the Markoff Spectrum. When $L(\alpha)$ is finite, the forms appearing in the construction are all equivalent to F , but the limiting form F^* is nonzero on all lattice points other than the origin and $L(\alpha) = M(F^*)$.

In this paper, we will concentrate on the inhomogeneous Markoff Spectrum, but applications to the inhomogeneous Lagrange Spectrum will follow by constructing a convergent sequence of reductions of the inhomogeneous expression $x(y - x\alpha - \beta)$.

4. THE INHOMOGENEOUS MARKOFF SPECTRUM

For *inhomogeneous* problems, the form F defined in (2) is replaced by

$$F_I(x, y) = (a_0x + b_0y + c_0)(a_1x + b_1y + c_1), \quad (7)$$

while we continue to require $(x, y) \in \mathbb{Z}^2$. Figures illustrating such problems will continue to be drawn in *viewing coordinates* for which $F_I(x, y) = 0$ on the axes of the coordinate system. The origin of this coordinate system is no longer required to be a lattice point. For example, Figure 2 modifies the example of Figure 1 by using factors $\xi_I = x + y\sqrt{3} - 1 - 0.5\sqrt{3}$ and $\eta_I = x - y\sqrt{3} - 1 + 0.5\sqrt{3}$ to study the expression $F_I(x, y) = \xi_I\eta_I$. Note that the origin is now at $(x, y) = (1, 0.5)$. The parallelogram in the figure has vertices whose (x, y) coordinates are $(0, 0)$, $(1, 1)$, $(2, 1)$, and $(0, 1)$ with edges that form a reduced basis. Earlier work has required that (c_0, c_1) not be in the lattice generated by (a_0, a_1) and (b_0, b_1) to explicitly exclude the homogeneous case. We propose to allow this case to *exclude itself* because it necessarily has a lattice point where $F_I(x, y) = 0$ and interest will be centered on those $F_I(x, y)$ that are bounded away from zero on the lattice. Notice that the parallelogram in Figure 2 has one vertex in each quadrant bounded by axes of F_I . This property defines a *divided cell*: the word “cell” refers to a fundamental parallelogram of the lattice, and it is “divided” by having its vertices separated by the axes.

The definition of the inhomogeneous Markoff value is

$$M_I(F_I) = \sup \left\{ \left| \frac{a_0b_1 - a_1b_0}{F_I(x, y)} \right| : x, y \in \mathbb{Z} \right\} \quad (8)$$

using the notation of (7). Note that the origin of the lattice is not excluded here, since it has no special role in F_I .

To describe an inhomogeneous problem, the matrix of (3) must be replaced by

$$B = \begin{bmatrix} a_0 & b_0 & c_0 \\ a_1 & b_1 & c_1 \end{bmatrix}. \quad (9)$$

Left multiplication by this matrix takes the column with components $(x, y, 1)$ to one with components (ξ_I, η_I) . Again, the rows of the matrix are the coefficients in the factors of $F_I(x, y)$. The interpretation of columns is a little different from the homogeneous case: the third column is the image of the origin, and the first two columns give generators of the lattice. If the matrix is augmented with a third row $[0 \ 0 \ 1]$, one gets the *affine*

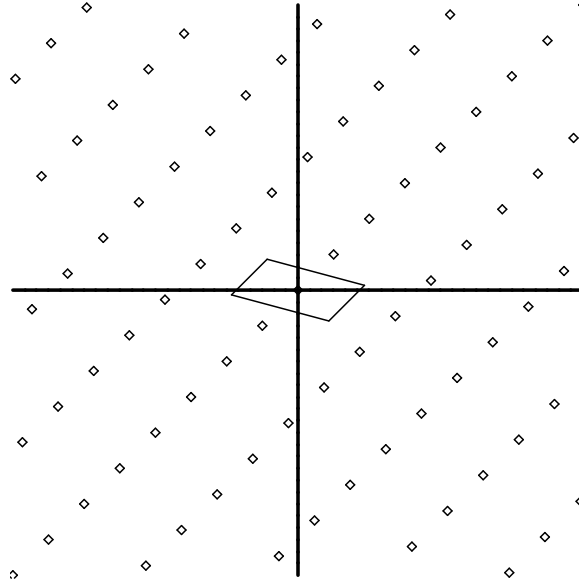

FIGURE 2. Inhomogeneous example

change-of-variables matrix relating the column with components $(x, y, 1)$ to one with components $(\xi_l, \eta_l, 1)$. In this matrix, a column with 0 in the third position represents a direction; one with 1 in the third position represents a point. The vertices of the cell are found by adding the sum of a subset of the first two columns to the third column. All such columns have 1 in the third position, so they can be expected to represent points.

Left multiplication by a two by two diagonal matrix changes the scale on the axes and right multiplication by an integer matrix with a third row $[0 \ 0 \ 1]$ and determinant ± 1 gives an affine change of basis in the lattice.

5. DIVIDED CELLS AS REDUCED OBJECTS

We continue the convention of using the (x, y) for coordinates in the integer lattice, but describing geometric properties using (ξ_l, η_l) as viewing coordinates.

Divided cells will be the reduced objects for the study of $F_l(x, y)$ on the integer lattice. Several proofs of the existence of divided cells have been given, beginning with Delone [6] in 1947. Our proof uses work of Pitman [7], and will be given after discussing the role of divided cells in Diophantine Approximation.

We choose the line $a_0x + b_0y + c_0 = 0$ to be the vertical axis in Figure 2 with the positive halfspace on the right. Treating the vertices of the cell as the basic fundamental parallelogram of \mathbb{Z}^2 with $(0, 0)$ in the lower left quadrant of the figure, gives $c_0 \leq 0, b_0 + c_0 \leq 0, a_0 + c_0 \geq 0, a_0 + b_0 + c_0 \geq 0$. These inequalities imply $a_0 \geq |b_0|$. A similar analysis of $a_1x + b_1y + c_1 = 0$ as the horizontal line leads to $b_1 \geq |a_1|$. Conversely, these conditions on a_0, a_1, b_0, b_1 give a nonempty set of possible solutions for c_0, c_1 . Since $M_l(F_l)$ is invariant under scaling of the linear factors of $F_l(x, y)$, one may introduce a convenient scaling, like $a_0 = b_1 = 1$. Then a_1 and b_0 are each chosen from the interval

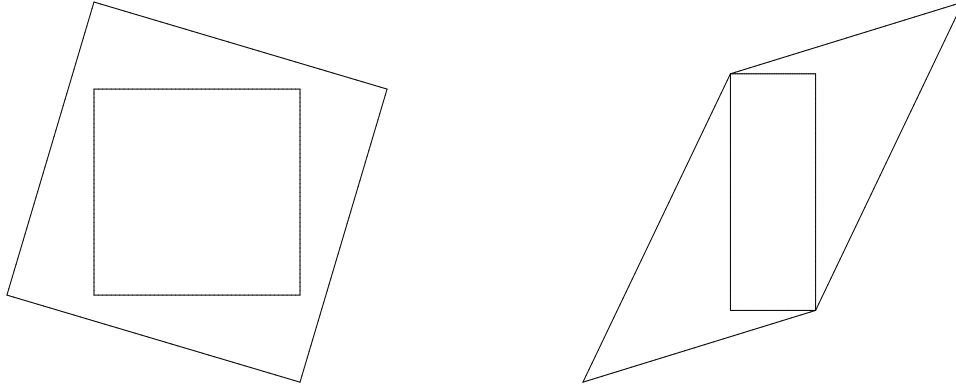

FIGURE 3. Cells and Boxes

$[-1, 1]$, and then each of c_0 and c_1 is chosen from an appropriate closed intervals. In this way, the space of divided cells can be represented by the fourth power of a closed interval. This scaling will not be used in this paper, but we will insist that $a_0 > 0$ and $b_1 > 0$, forcing the *base vertex* to be in the third quadrant.

This construction shows that the specification of a divided cell can be done in two steps: first choose generators of the lattice giving the directions of the sides of the cell; then locate the origin. Barnes [1] introduced the term “I-reduced” for the lattice bases arising in this way. We keep the name, but take it to mean that $a_0 \geq |a_1|$ and $b_1 \geq |b_0|$.

If $a_1 b_0 \leq 0$, the cells are essentially the reduced cells of the homogeneous case. Such cells will be called *Gaussian*, or G-cells, indicating that they are reduced in the sense of Gauss. Note that, in contrast to the homogeneous case, no attempt is made to fix the sign of a_1 .

The cells that are *not* Gaussian will be called N-cells. Since definitions should use *inclusive* inequalities, the correct characterization of an N-cell is $a_1 b_0 \geq 0$. This allows a cell to be both a G-cell and an N-cell, but only when one of its sides is parallel to an axis.

If a parallelogram is an I-reduced cell, then the possible locations of the origin in the cell form a rectangle inside the cell. This rectangle is called the *inner box* (which we will sometimes call simply a “box”) of the I-reduced cell. Figure 3 shows two typical examples. In the figure, a G-cell is on the left and an N-cell is on the right. The width of the box is $a_0 - |a_1|$, so that it degenerates to a vertical line segment if $a_0 = |a_1|$. Similarly, the inner box degenerates to a horizontal line segment if $b_1 = |b_0|$. When both $a_0 = |a_1|$ and $b_1 = |b_0|$, the box is only a single point. This illustrates that the first row, which gives the coefficients in the equation of the axis shown in the vertical position and describes the first coordinates of the cell, governs the divided cell step. As in the homogeneous case, the partial order defining minimal points considers distances to both axes. However, this time it is necessary to treat each quadrant separately. Within a fixed quadrant, points that are closer to both axes will be smaller points in the partial order. We call this the *basic partial order*. It will need to be modified, but this is a good tentative definition.

6. THE DIVIDED CELL ALGORITHM

Once one divided cell is available, it is possible to construct a *chain* of divided cells containing that cell. This construction is the *Divided Cell Algorithm*. It must be shown that $M_I(F_I)$ can be computed using only the vertices of the cells obtained by this algorithm. This is essentially the content of Theorem 5 of [2]. Another approach to using divided cells to compute $M_I(F_I)$ is given by the theorem on page 530 of [6]. Our proof will distinguish *six* related chains arising from the divided cell algorithm: a chain of cells, a chain of boxes, and four chains of minimal points. The relations among these chains is not as direct as it is in the homogeneous case, so it is useful to keep them separate while showing how they are related. The chains of minimal points — one chain in each quadrant — play a key role in showing that all divided cells lie in a single chain and are used to characterize the quantity $M_I(F_I)$ defined in (8). Since the chains in different quadrants are independent, distances in different quadrants may be weighted differently. We don't explore that here, but some consequences can be found in Section 3 of [2]. Finally, the chain of boxes shows the simplest progression from one axis to the other. All of these chains terminate if there is a lattice direction parallel to an axis, but our statements will make no effort to distinguish that case.

The construction of the Divided Cell Algorithm is used in two settings: given expression F_I , it produces its chain of divided cells; given only an I-reduced basis for a lattice, it describes all possible successor I-reduced bases.

Theorem 1. *If F_I admits one divided cell, then there is a chain of divided cells containing that cell. Given an I-reduced basis, there is one shape of an N-cell arising as a successor and one possible shape of a G-cell arising as a successor. The N-cell always occurs, but the G-cell may not: the number of positions of the N-cell is always one more than the number of positions of the G-cell.*

Proof. Suppose that we are given a divided cell defined by a matrix as in (9). Since this is a divided cell, $a_0 \geq |a_1|$ and $b_1 \geq |b_0|$, with additional bounds on each c_i in terms of a_i and b_i . The details of the divided cell step depend on the sign of b_0 . The algorithm terminates if $b_0 = 0$, and there are only minor differences between the other cases, so only the case of $b_0 > 0$ will be illustrated.

The definition of a divided cell then gives that $c_0 < c_0 + b_0 \leq 0 \leq c_0 + a_0$, so that the line segment from (c_0, c_1) to $(c_0 + b_0, c_1 + b_1)$ forms the left side of the cell and crosses the horizontal axis. This side can be extended until it crosses the vertical axis, giving an integer $h > 0$ with $c_0 + hb_0 \leq 0 \leq c_0 + (h + 1)b_0$. The segment from $T_- : (c_0 + hb_0, c_1 + hb_1)$ to $T_+ : (c_0 + hb_0 + b_0, c_1 + hb_1 + b_1)$ will form the *top* of the next cell. Similarly, the bottom of the next cell is found by extending the right side to get a segment from $B_- : (c_0 + a_0 - kb_0, c_1 + a_1 - kb_1)$ to $B_+ : (c_0 + a_0 + b_0 - kb_0, c_1 + a_1 + b_1 - kb_1)$ for some $k > 0$. Since segments T_-T_+ and B_-B_+ both cross the vertical axis, it follows that $(h + k - 1)b_0 \leq a_0 \leq (h + k + 1)b_0$. This analysis shows that right multiplication by

$$S = \begin{bmatrix} 0 & -1 & 1 \\ 1 & h+k & -k \\ 0 & 0 & 1 \end{bmatrix} (b_0 > 0) \text{ or } S = \begin{bmatrix} 0 & 1 & 0 \\ -1 & h+k & 1-h \\ 0 & 0 & 1 \end{bmatrix} (b_0 < 0) \quad (10)$$

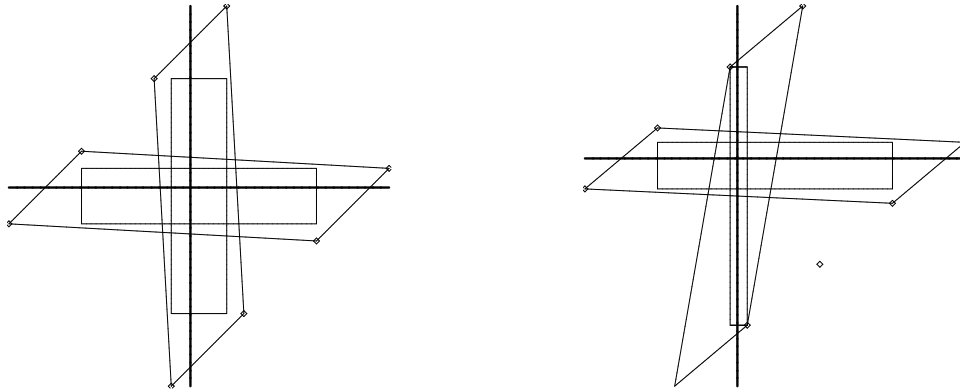

FIGURE 4. Successor Cells and Boxes

gives the matrix representing the next cell. In each case, h and k are positive integers with $(h+k-1)|b_0| \leq a_0 \leq (h+k+1)|b_0|$. If a_0/b_0 is not an integer, $h+k$ must be one of the two integers nearest to $|a_0/b_0|$.

The *shape* of the successor cell is determined by $h+k$; and the *position* by h . Those with different h and the same $h+k$ are translates of one another. The leftmost possible cell is an N-cell with $h=1$ and k as large as possible. If $|a_0/b_0| < 2$, this is the only successor. Otherwise, the rules for determining the inner box show that decreasing k by 1 and keeping h fixed gives a G-cell whose inner box abuts the box of this leftmost cell. Then, keeping this k and increasing h by 1 gives a *translate* of the leftmost N-cell whose inner box abuts the box of this G-cell. The rightmost box will be an N-cell, and the union of the inner boxes of these possible successors covers the inner box of the original cell. \square

Note that the first row of (9), which gives the coefficients in the equation of the axis shown in the vertical position and describes the first coordinates of the cell, governs the divided cell step.

The first part of Theorem 1 is illustrated in Figure 4 showing a divided cell with its box and, in two separate graphs, two successor cells with their boxes. In this picture, the original cell is a G-cell, and both types of successor are shown with the G-cell on the left (note that this figure contains G-cells with different signs of a_1). Several lattice points are also included.

Figure 4 may also be used to analyze the chain of divided cell vertices in each quadrant. In the pictures, the common lattice direction of a cell and its successor gives a line joining the vertices of those cells in the second quadrant, and also in the fourth quadrant. Moreover, these two lines are adjacent lattice lines in that direction, so that there are no lattice points interior to the strip bounded by those lines. However, in the fourth quadrant of the second picture there is a point on one of these lines that is not a vertex of a divided cell although it meets our preliminary requirement for being a minimal point. We will now resolve this difficulty. We state the theorem for the first quadrant in order to have names for the edges that we use, and concentrate on points with small first coordinate but the proof is readily applied to both coordinates in all quadrants.

Theorem 2. *Given a divided cell C , let I be the projection of the open top edge of C on the horizontal axis. For each lattice line L parallel to this edge, let I_L be the points on L whose projection on the horizontal axis lies in I . Then each I_L contains at most one lattice point, and only those above the top edge of C contain such a lattice point in the first quadrant. Furthermore, the projections onto the vertical axis of the I_L are disjoint, so the ordering of these points by their second coordinate is the same as the order on the line L containing the point.*

Proof. For a lattice line L , the distance between consecutive lattice points on L is fixed, and the top edge of C gives one example of such a pair of consecutive lattice points. Again, since the lines are parallel, the difference of first coordinates is also fixed and equal to the width of I in this case. Hence, except when the endpoints of I_L are lattice points, there is a unique lattice point in each I_L .

Similarly, the relation between projections on the vertical axis of two consecutive I_L is also fixed, so it will be the same as the relation between the projections of the top and bottom edges of C . However, C is a divided cell, so all points on the top edge have positive second coordinate and all points on the bottom edge have negative second coordinate, so the projections of these edges are disjoint. For L below the top edge of C , all points of I_L have negative second coordinate, so I_L contains no point in the first quadrant. \square

Any point in the first quadrant that is closer to the vertical axis than the vertex P of C in that quadrant must project into I , but Theorem 2 shows that all lattice points with that property have larger second coordinate than P . Hence P is a minimal point.

When a side of C is extended to meet the positive vertical axis, one obtains a lattice line with one lattice point on each line parallel to the top edge of C . When the left side of the C is used in this construction, the first description of the divided cell step shows that the first lattice point in the first quadrant is a vertex of the successor divided cell. If it is the extension of the right side of C that meets the positive vertical axis, the first several lattice points will be in the first quadrant, but only the first and last of these are vertices of divided cells. This bypassing of minimal points in the divided cell algorithm is easily accommodated by augmenting the basic partial order.

Theorem 3. *If a line meets a quadrant in a bounded interval, the product of the distances to the axes is zero at the endpoints of the interval and has a unique interior maximum. The distance decreases as one moves from the location of the maximum towards either axis.*

Proof. A calculus exercise! When expressed in terms of one of the coordinates the distance is a quadratic polynomial with negative coefficient of the second degree term. \square

When the line in Theorem 3 is a lattice line, this says that we may modify the basic partial order to also say that a lattice point is greater than another lattice point on the line that is on the same side of the point of maximum value of F_l and farther from that point. With this modification, the only minimal points on the line in this quadrant are the vertices of the original divided cell and its successor.

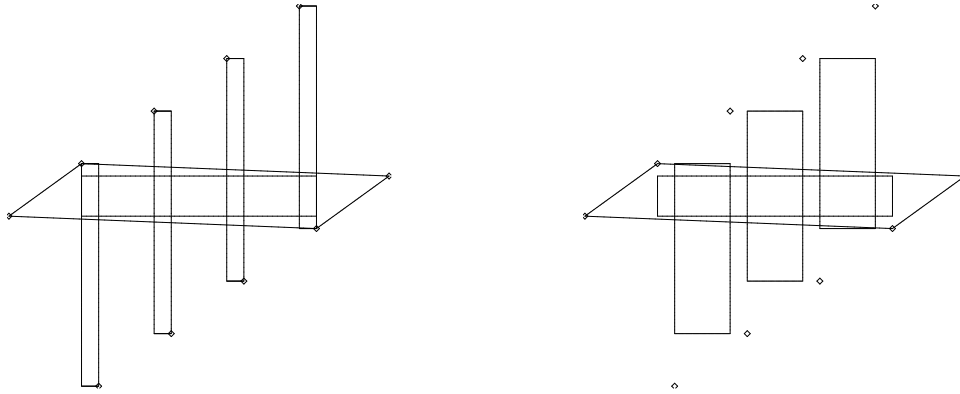

FIGURE 5. All Successor Boxes

Augmenting the basic partial order in this way on *every* lattice line and forming the transitive closure gives a new partial order called the *extended partial order* with fewer minimal points. We will say the P is *nearer* that Q if $P \leq Q$ in the extended partial order.

Theorem 4. *If divided cells exist, every minimal lattice point for the extended partial order is a vertex of a divided cell.*

Proof. This is now little more than using a known divided cell as the basis and using previous results of this section for an induction step. By symmetry, it suffices to show the result for a minimal lattice point P in the first quadrant that is closer to the vertical axis. By Theorem 2 there are finitely many minimal lattice points whose second coordinate lies between that of P and the original divided cell vertex in this quadrant. By the discussion following Theorem 3, the first of these is the vertex of a divided cell. There are fewer minimal lattice points in the first quadrant between this cell and the selected point, allowing induction to work. □

We illustrate the second part of Theorem 1 with Figure 5 showing the inner boxes of the possible successors. To draw both Figure 4 and Figure 5, we used $a_0/a_1 = 2 + \sqrt{5} \approx 4.236$. The two parts of Figure 5 show the number of each type of cell predicted by Theorem 1. To avoid clutter, the cells are not shown in Figure 5, but the vertices are. Note that lattice points appear as vertices of the inner box of an N-cell, but the inner box of a G-cell is strictly interior to the cell and contains no lattice point. The cells that are collected in each of the pictures in Figure 5 are translates of one another in agreement with the expressions for their vertices appearing in the proof of Theorem 1. What Figure 5 shows is that the inner boxes of two successor cells intersect in at most a vertical segment and that the union of all of these boxes covers the inner box of the original cell.

Combining this with the proof of Theorem 4 we find that the chain of boxes shows a systematic increase of height and decrease of width as we step through the chain.

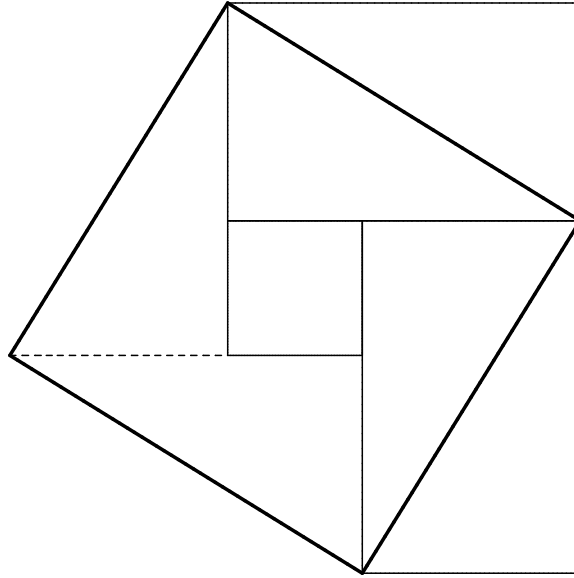

FIGURE 6. Three boxes form a fundamental domain

7. PITMAN'S THEOREM

Jane Pitman [7] related divided cells, which are the reduced cells of an inhomogeneous approximation problem, to the reduced bases of the corresponding homogeneous problem given by the continued fraction algorithm. Consequences of her work are an easy proof of the existence of divided cells (given here as the Corollary to Theorem 5) and tools for recognizing minimal points.

Theorem 5. *The cell of a Gaussian reduced form gives rise to two I-reduced N-cells. If the Gaussian cell has $a_1 \geq 0$, then the matrices corresponding to the other cells are obtained by multiplying its matrix by*

$$\begin{bmatrix} 1 & 0 & 0 \\ 1 & 1 & 0 \\ 0 & 0 & 1 \end{bmatrix} \text{ or } \begin{bmatrix} 1 & -1 & 1 \\ 0 & 1 & 0 \\ 0 & 0 & 1 \end{bmatrix}. \quad (11)$$

The union of the inner boxes of these three cells is (apart from duplication on the boundary) a fundamental domain for the lattice.

Proof. Figure 6 gives a “proof without words”. It illustrates how the fundamental domain of the given Gaussian cell may be cut into pieces that may be translated and re-assembled to form the union of the three boxes described in the statement of the theorem. The parallelogram whose sides are not horizontal or vertical is the given cell. The box in the center of the figure is the inner box of this cell. The other boxes are the inner boxes of N-cells described in the statement of the theorem. The dashed line divides the part of the original cell outside the boxes into pieces congruent to the portions of the boxes outside the cell. \square

Corollary. *Every linear inhomogeneous problem in \mathbb{R}^2 has divided cells.*

Proof. Employ the homogeneous theory to reduce the linear part $(a_0x + b_0y)(a_1x + b_1y)$. Then locate the intersection of the axes in Figure 6. The cell corresponding to that box is a desired divided cell. \square

The N-cells described by Theorem 5 are called the *neighbors* of the G-cell in that theorem. One of these neighbors is characterized by $|a_0/b_0| \geq 2$; the other by $|b_1/a_1| \geq 2$. Conversely, each of these inequalities allows the construction of a neighboring G-cell of a given N-cell.

If both inequalities hold, then the N-cell serves as an immediate link between consecutive reductions of the linear part of $F_I(x, y)$. However, it is also possible to find N-cells for which neither of these will hold, so that they are not neighbors of a G-cell. Such cells will be considered in the next section.

The boxes shown in Figure 6 give the matrices shown in (11). The third column affects only the location of a cell and not its shape, and is significant only for describing cells having some particular relation to the original G-cell.

When $a_1 \leq 0$, the transition matrices of (11) are replaced by

$$\begin{bmatrix} 1 & 1 & 0 \\ 0 & 1 & 0 \\ 0 & 0 & 1 \end{bmatrix} \text{ or } \begin{bmatrix} 1 & 0 & 0 \\ -1 & 1 & 0 \\ 0 & 0 & 1 \end{bmatrix}. \quad (12)$$

(If $a_1 = 0$, its sign should be chosen opposite to the sign of b_0 ; if $a_1 = b_0 = 0$ the different constructions only involve cells with degenerate boxes.)

8. SUPERFLUOUS CELLS

This section investigates the role of the I-reduced cells that are neither G-cells nor neighbors of G-cells. We refer to such cells as *superfluous cells* for a reason that is given in Theorem 6.

Figure 7 shows the portion of a chain of divided cells starting with a cell C_- for which $-2 < a_0/b_0 < -1$ and $b_1/a_1 < -2$ (the values used when drawing the figure were $-(3 + \sqrt{5})/4 \approx -1.309016994$ and $-(3 + \sqrt{5}) \approx -5.236067977$). The figure also includes the inner box of the first cell that is seen to also be the inner box of *all* cells shown. All but the last of these has a unique successor, and the figure shows this chain of unique successors. The last cell shown, C_+ , has $a_0/b_0 < -2$, so there will be a choice of possible successors, none of which are shown. For all the cells C shown in Figure 7, the cell C_+ will be called the *forward anchor* of C and C_- will be called the *backward anchor* of C .

Theorem 6. *For superfluous cell, the anchors are uniquely determined. For every vertex of a superfluous cell, a vertex of one of the anchors is nearer in the extended partial order.*

Proof. Since $1 \leq |a_0/b_0| \leq 2$, the proof of Theorem 1 shows that the divided cell algorithm involves a unique successor that is also an N-cell. As long as that cell is superfluous, the algorithm generates a unique forward chain. A closer examination of the function giving a_0/b_0 for the successor in terms of the corresponding quantity in the original cell is an expansive mapping with ± 1 as fixed points. From this, it follows that,

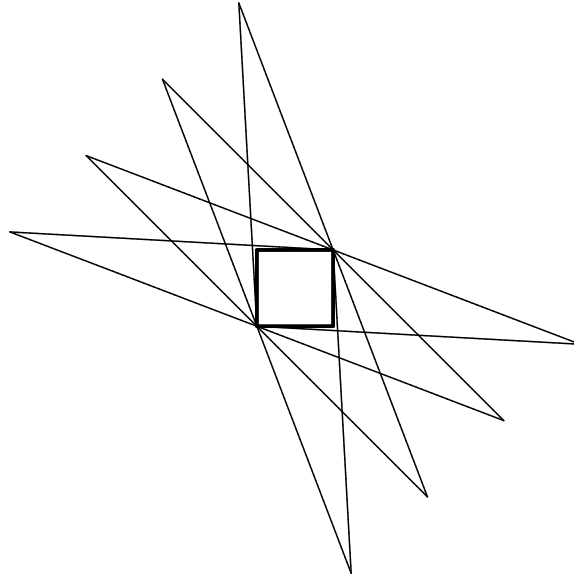

FIGURE 7. Superfluous cells

apart from degenerate cases, the chain starting from any superfluous cell will reach a neighbor of a G-cell in a finite number of steps (this is not difficult to show, but the details are awkward to express, so they will be omitted). The process stops at the *forward anchor* of the superfluous cell. The process of stepping backwards through the chain of divided cells is governed by the ratio b_1/a_1 in the same way, leading to the *backward anchor* of the original cell. Thus, Figure 7 describes the *only* way that superfluous cells can occur and relates these cells to the anchors. A study of the explicit matrix relating a superfluous cell to its successor shows that the anchors are attached to consecutive reduced bases of the lattice.

Two of the vertices of a superfluous cell are also vertices of its inner box. These will be called the *inner vertices* of the cell. The inner vertices are shared with all cells shown in Figure 7 including the anchors, so they have now been found in a non-superfluous cell.

The remaining vertices of the cells in Figure 7 (the *outer vertices*) lie on a lattice line parallel to and adjacent to the line joining the inner vertices, and one of the vertices of an anchor will be nearer in the extended partial order than a given outer vertex of a superfluous cell. \square

9. A RIGOROUS FRAMEWORK

The emphasis here has been visual. Figures were used to illustrate the constructions and proofs. These figures were drawn using the *Maple* Symbolic Computation System. In order to tell the system what to draw, the cells and boxes were represented by matrices like B of (9).

The visual approach was present in [6], but was not used much by subsequent authors. Computers have facilitated the re-introduction of graphics into exposition, including the

use of color where appropriate (the figures in this paper were presented in color at the conference). At the same time, increasing fluency in the language of Linear Algebra has encouraged the use of matrices to represent the objects met in the study. Our intent here was to use these developments to present old results in a way that will encourage new research.

Some weaknesses of the Divided Cell *Algorithm* have appeared in our exposition, but we have also shown that its application to Inhomogeneous Diophantine Approximation can rely on methods like the ordinary continued fraction that are associated to the Homogeneous Markoff Spectrum. Divided Cells become a tool for organizing the subject rather than a device for computing properties of individual problems.

ACKNOWLEDGMENTS

We thank Takao Komatsu for all he did to make to make this conference a success. We acknowledge the funding that he obtained for our participation in the conference.

The inspiration to study divided cells came from Bill Moran. We also acknowledge the funding that brought us (separately) to Adelaide for that work and apologize for the long delay in producing the fruits of that work.

REFERENCES

1. E. S. Barnes. The inhomogeneous minima of binary quadratic forms. IV. *Acta Math.*, 92:235–264, 1954.
2. E. S. Barnes and H. P. F. Swinnerton-Dyer. The inhomogeneous minima of binary quadratic forms. III. *Acta Math.*, 92:199–234, 1954.
3. Richard T. Bumby. The continued fraction algorithm approached through quadratic forms. *Rancho University Mathematical Journal*, 22:1–24, 1991.
4. John H. Conway. *The sensual (quadratic) form*, volume 26 of *Carus Mathematical Monographs*. Mathematical Association of America, Washington, DC, 1997. With the assistance of Francis Y. C. Fung.
5. Thomas W. Cusick and Mary E. Flahive. *The Markoff and Lagrange spectra*, volume 30 of *Mathematical Surveys and Monographs*. American Mathematical Society, Providence, RI, 1989.
6. B. N. Delone. An algorithm for the “divided cells” of a lattice (in Russian). *Izvestiya Akad. Nauk SSSR. Ser. Mat.*, 11:505–538, 1947.
7. Jane Pitman. The inhomogeneous minima of a sequence of Markov forms. *Acta Arithmetica*, V:81–116, 1958.